

ACCEL+

Neurostimulation System



SIMPLIFI[®]
Neuromodulation Solutions Platform

SIMPLIFI[®]

Neuromodulation Solutions Platform

The SIMPLIFI[®] Neuromodulation Solutions Platform offers uncompromising consulting, manufacturing, customization and engineering simplicity for advanced research and new product development. Lower the risk. Speed the success of your novel therapy or next generation device.

The platform consists of ACCEL+ and ACCEL, two neuromodulation systems that help turn concepts into clinical and commercial success.

The ACCEL+ Neurostimulator System is our most complete solution for your successful product launch.



ACCEL+

A COMPLETE SOLUTION

The ACCEL+ System can be used to advance research or to support your commercialization requirements.

The ACCEL+ Neurostimulator System is our most complete solution for your successful product launch.

- Harness your regulatory strategy by leveraging the Device Master File on record with the FDA.
- Choose from a full suite of peripherals, leads, and surgical instruments.
- Ideal for research, early feasibility studies, and accelerated launch strategies.
- Manufactured and configured to your specifications.

WORKING TOGETHER

Partnering with us brings you closer to turning your innovative ideas into breakthrough therapies.

- Whether your goal is to bring a novel therapy to market or rapidly move to a next generation design suitable for high volume manufacturing, we can help.
- With more than three decades of experience, we understand the technical, practical and regulatory issues needed to bring new and next generation products to market.
- You can work confidently knowing our platform meets the highest quality standards.

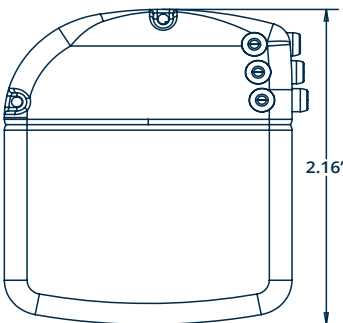
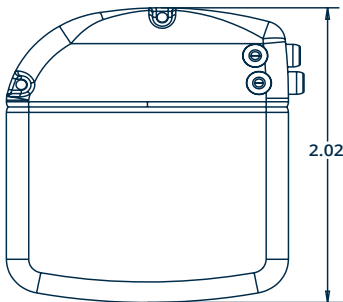

IMPLANTABLE PULSE GENERATOR

- Two configurations
 - ▶ 3 ports x 8 independent channels (3 leads, each with 8-electrodes)
 - ▶ 2 ports x 12 independent channels (2 leads, each with 12-electrodes)
- 24 dedicated current sources (0 to 15 mA per channel - 30mA total output maximum)
- Enhanced wireless communication capabilities
- Rechargeable, deep-discharge recovery battery
- Biphasic Square Pulse Shape
- Small volume (19.5 and 20.5 cc)



EXTERNAL PULSE GENERATOR

- EPG functionality identical to IPG
- Extensions in 1x8 and 1x12 configurations
- Patient controlled using the Pocket Programmer
- Number of programs – 1 to 10
- Number of sub-programs per program – 1 to 4
- Electrode configuration: Up to two 12 electrode leads or three 8 electrode leads
- Trial percutaneous leads (identical in construction to permanent leads)
- Amplitude
 - ▶ Upper patient limit 15.0 mA
 - ▶ Lower patient limit 0.017 mA
- Pulse width – 20 to 1500 μ s (20- μ s resolution)
- Frequency
 - ▶ Upper patient limit 2000 Hz
 - ▶ Lower patient limit 2 Hz
- Power source – 2 AAA batteries
- EPG housing made of polycarbonate material



POCKET PROGRAMMER

- Key fob sized rechargeable programmer used to operate IPG/EPG
- Uses MICS telemetry to communicate with the IPG/EPG
- Basic functions:
 - ▶ Turn stimulation on/off
 - ▶ Adjust stimulation strength
 - ▶ Displays battery status for both the IPG and programmer









PROGRAMMER CHARGER

- Patient hand-held, rechargeable touch screen device and a detachable charging paddle
- Dual functions:
 - ▶ Recharges the IPG
 - ▶ Provides advanced programming options
- Optional adjustable belt and adhesive patches hold charging paddle over the site of the IPG while it recharges

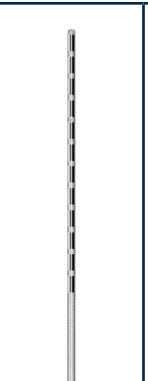

LEADS

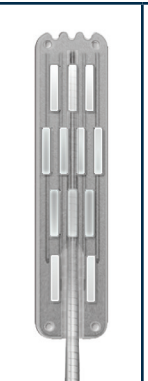
- Percutaneous leads available in multiple lengths and three electrode spacing options
- 1x8 and 1x12 lead extensions provide additional length
- 8- and 12-electrode trial lead kits available in compact or standard electrode spacing options
- All leads are constructed with biocompatible materials

ACCEL+ LEAD PORTFOLIO						
	Lead Type	1x8 Percutaneous COMPACT	1x8 Percutaneous STANDARD	1x12 Percutaneous COMPACT	1x12 Percutaneous STANDARD	3-4-3-2 Paddle
Electrode Height (mm)	3mm	3mm	3mm	3mm	6mm	6mm
Vertical Electrode Spacing (mm)	1mm	4mm	1mm	4mm	2mm	2mm
Lead Lengths (cm)	45, 60, 75	45, 60, 75	45, 60, 75	45, 60, 75	45,60	45,60

ASIC OPTIONS	CSI020	CSI040	CSI040	Saturn1	Saturn2
Number of independent channel outputs	32	4	16	26	26
Maximum single channel output current (mA)	12.7	6.12	25.4	15	15
Maximum stimulation voltage (V)	18	18	18	18	23
Maximum pulse frequency (kHz)	14.25	12.5	50	50	50
Pulse width range (µs)	20 -1000	10 - 2550	2.5 - 1280	1 - 1500	1 - 1500
Pulse width resolution (µs)	10	10	2.5	1.0	1.0
Simulation type	Bipolar	Monopolar	Monopolar or Bipolar	Monopolar or Bipolar	Monopolar or Bipolar
Minimum supply operating voltage (V)	3.5	2.4	2.4	2.4	2.4
Integrated battery charge controller	Yes	No	No	No	No



Cirtec Medical is a vertically integrated, full-service outsource partner providing end-to-end product design, development and manufacturing of Class II and III medical devices and components. We specialize in today's most advanced product technologies, including: neuromodulation, implantable drug delivery, cardiac rhythm management, ventricular assist, structural heart and minimally invasive systems.

Learn More



Cirtecmed.com